

## High Pressure Carbon Dioxide

## Pressure Operated Siren

### Description

The pressure operated siren is used to warn personnel prior to a system discharge. The siren is operated with the carbon dioxide pressure from the system. The siren will operate upon activation of the pilot cylinder(s) and will continue through most of the discharge time. The minimum decibel level at 10 ft (3 m) is 90 dB with a flow rate of 13.6 lb/minute (6.1 kg/minute). A pipe hanger or bracket must be installed within one foot of the siren. The siren is painted red.

| Shipping Assembly Part No. | Description             |
|----------------------------|-------------------------|
| 419700                     | Pressure operated siren |

| Component | Material   | Specifications  | Approvals  |
|-----------|--|---|--|
| Siren     | Body: Brass<br>Grill: Steel<br>Screen: Stainless Steel | Required Pipe: 1/4 in., Schedule 40<br>Maximum Sirens: 4<br>Maximum Pipe Length: 200 ft (61 m) minus 1 ft (0.3 m) for every elbow used<br>Flow Rate: 13.6 lb/minute (6.1 kg/minute)<br>Design of system must include agent used through siren if siren is not located in hazard area. | UL Listed (EX-4510)<br>Listed for use with FM Approved systems |

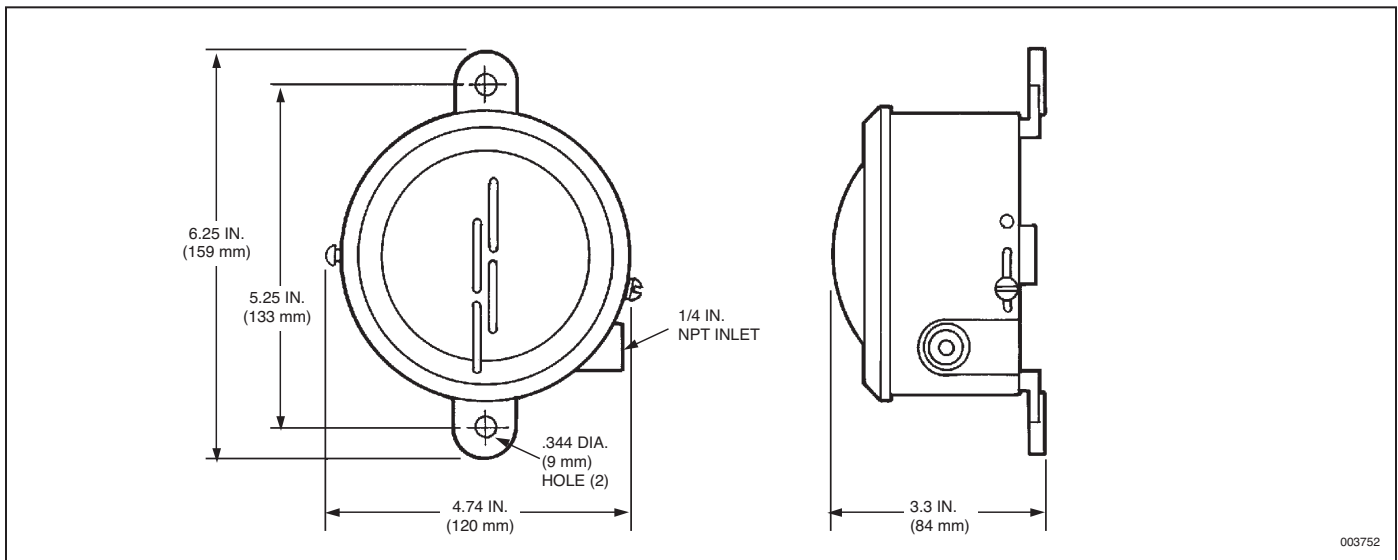

003752