

900 lb. FM-200[®] Cylinder

P/Ns: 93-100900-001 & 93-100901-001



F-93-9044

FEATURES

- Large Capacity FM-200[®] Cylinder
- 3-Inch Discharge Valve
- Optional Liquid Level Indicator
- Optional Low-Pressure Switch (P/N 06-118263-001)
- FM Approved
- UL Listed
- TC Approved

DESCRIPTION

Fenwal FM-200[®] 900 lb. cylinders store FM-200 super-pressurized with dry nitrogen to 360 psig at 70°F (2.48 Mpa at 21°C). The cylinders are painted red and are equipped with a 3-inch pressure differential valve, pressure gauge, optional liquid level indicator and optional low-pressure switch assembly. The pressure relief device is also located on the cylinder head.

OPERATION

The agent storage container discharges when the actuation assembly operates, causing the pressure differential valve to open. All of the Fenwal actuators may be used to actuate the 900 lb. cylinder. The only exception is the 48650001, which is not compatible with this cylinder valve.

INSTALLATION

The container is installed in a vertical position with the valve assembly pointing up. Interconnection to discharge piping is 3-inch NPT. Interconnection can be via a 3-inch flex hose (P/N 06-118225-001) or via a suitably pressure rated groove style fitting.

The container is secured in place by a mounting bracket (P/N 236125), which must be fixed to a solid wall or strut assembly. After the container is securely mounted it is connected to discharge piping per the directions in the design manual.

An optional cylinder supervisory pressure switch (P/N 06-118262-001) can be installed on the cylinder valve in the field if required. This cylinder supervisory pressure switch has a 1/8-inch NPT connection, which is used on the 3-inch valve only. For cylinder valves manufactured prior to May 1, 2013, use supervisory pressure switch P/N 06-118263-001.

ORDERING INFORMATION

The part number for ordering the 900 lb. FM-200 cylinder without liquid level indicator is 93-100900-001. The part

number for ordering the 900 lb. FM-200 cylinder with liquid level indicator is 93-100901-001.



MAINTENANCE

According to NFPA standards the following inspection and/or maintenance procedure must be scheduled as listed below and performed upon the occurrence of any event which might affect the reliability of the system.

QUARTERLY INSPECTION

1. Check the pressure gauges of each agent storage container. If the pressure gauge indicates a loss in pressure of 10% or more, then it shall be recharged or replaced. Pressure varies with temperature, and this must be taken into account when checking the pressure gauge. In the range of 55°F to 85°F (13°C to 29°C) the change is approximately 3 psi per degree F.
2. Check all components, including supporting hardware, and tighten, repair or replace as required.

3. Replace any component if at all in doubt of its ability to perform properly.

SEMI-ANNUAL INSPECTION

Qualified personnel should determine the amount of agent in all containers. The optional liquid level indicator may be used to measure agent supply and compare it to the original net weight which is marked on the container label. If the measured net weight is less than 95% of the original charged weight the container should be recharged or replaced.

Inspect all piping, fittings and nozzles for looseness, dirt or other damage. All outlet piping must be clean and free of dirt, chips, fillings and other foreign material that may cause the system to become inoperative or ineffective at the time of discharge.

SPECIFICATIONS

Part Number	93-100900-001 93-100901-001		93-100900-001 93-100901-001
Fill range (lb.)	390-900	Fill range (kg)	178-408
Height (in.)	70	Height (mm)	1789
Diameter (in.)	24	Diameter (mm)	610
Internal volume (cu. ft.)	13.0	Internal volume (cu m)	0.368
Empty weight (lb.)	505	Empty weight (kg)	229
Temperature range	32°F to 130°F	Temperature range	0°C to 54°C
Safety relief burst range	800 to 975 psig	Safety relief burst range	5.5 to 6.7 Mpa
Construction specification	DOT 4BW-500	Construction specification	DOT 4BW-500

ACCESSORIES

Description	Part number
3-inch stainless steel flexible hose	06-118225-001
3-inch swing check valve	06-118058-001
Cylinder bracket	06-236125-001
Cylinder supervisory pressure switch	06-118262-001*

*For cylinder valves manufactured prior to May 1, 2013 use supervisory pressure switch P/N: 06-118263-001.

DIMENSIONS

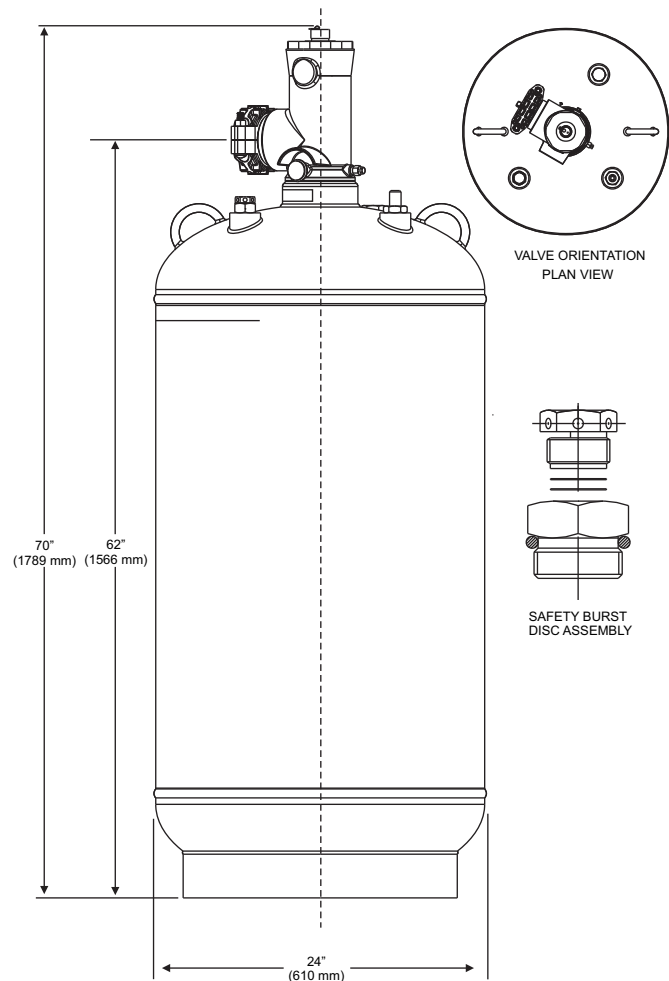

This literature is provided for informational purposes only. KIDDE-FENWAL, INC. assumes no responsibility for the product's suitability for a particular application. The product must be properly applied to work correctly. If you need more information on this product, or if you have a particular problem or question, contact KIDDE-FENWAL, INC., Ashland, MA 01721. Telephone: (508) 881-2000.



400 Main Street
Ashland, MA 01721
Ph: 508.881.2000

Tech Support: 866-287-2531
www.fenwalfire.com