

Fenwal Engineered Fire Suppression System

Designed for use with 3M™ Novec™ 1230 Fire Protection Fluid

3-inch Swing Check Valve Data Sheet

F-44-9040



A UTC Fire & Security Company

P/N: 06-118058-001

FEATURES

- For use with UL Listed, ULC Listed, and FM Approved Systems

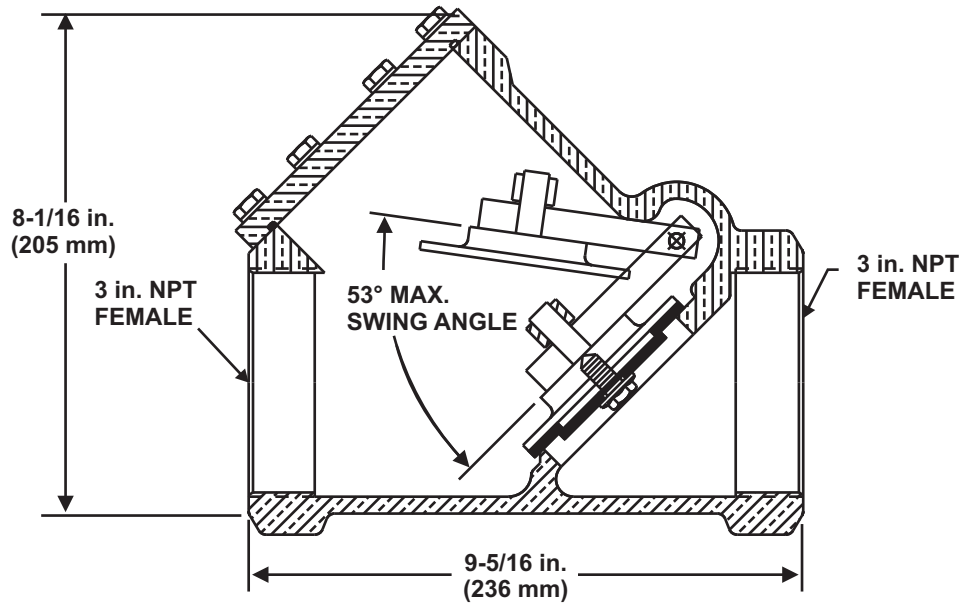

Note: The valve must be installed with the arrow pointing in the direction of flow.

MATERIALS

- Valve Body and Cover: Brass
- Hex Bolts, Hinge, and Hinge Pin: Stainless Steel

APPROVALS

- UL Listed
- ULC Listed
- FM Approved

Fenwal is a registered trademark of Kidde-Fenwal, Inc.
3M and Novec are trademarks of 3M.
All other trademarks are property of their respective owners.

This literature is provided for informational purposes only. KIDDE-FENWAL, INC. assumes no responsibility for the product's suitability for a particular application. The product must be properly applied to work correctly.
If you need more information on this product, or if you have a particular question, contact KIDDE-FENWAL, INC., Ashland, MA 01721. Telephone: (508) 881-2000.

Fenwal Protection Systems
A UTC Fire & Security Company
400 Main Street
Ashland, MA 01721
Ph: 508.881.2000
Fax: 508.881.8920
www.fenwalfire.com