

Fenwal Engineered Fire Suppression System

Designed for use with 3M™ Novec™ 1230 Fire Protection Fluid

3-inch Flexible Discharge Hose Data Sheet

F-44-9045



A UTC Fire & Security Company

P/N: 06-118225-001

FEATURES

- Stainless Steel Braided
- Victaulic Fittings
- FM Approved
- UL Listed

DESCRIPTION

Stainless Steel flexible hose is used to connect the 3-inch valve cylinders (both the 600 and 900 lb. cylinders) to discharge piping. The hose has a victaulic fitting at the cylinder end and a 3-inch male groove fitting to connect to the piping.

INSTALLATION

The stainless steel flexible braid hose may be installed horizontally or with a 90 degree bend radius as shown in the diagram below.

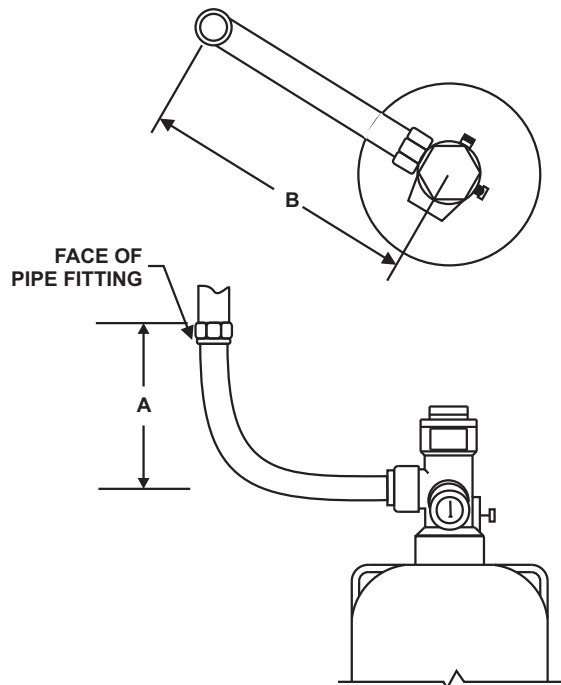

Note: Dimension A and B must be maintained in order to obtain a smooth radius in flexible loop. Hose may require adapter to connect to system piping.

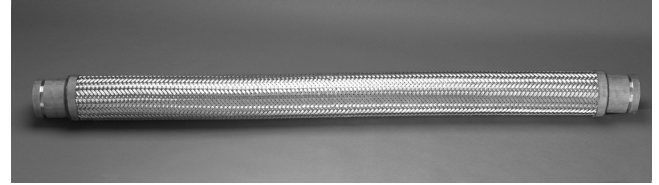

ORDERING INFORMATION

The part number for ordering the 3-inch flexible discharge hose is 06-118225-001.

SPECIFICATION

Material:	Convolutod hose with stainless steel braid overlay
Working Pressure:	500 PSI (3.4 Mpa)
Proof Pressure:	1000 PSI (7.0 Mpa)
Burst Pressure:	2000 PSI (13.8 Mpa)

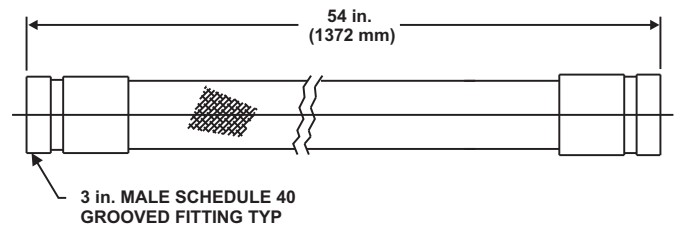

Fenwal is a registered trademark of Kidde-Fenwal, Inc.
3M and Novec are trademarks of 3M.
All other trademarks are property of their respective owners.

This literature is provided for informational purposes only. KIDDE-FENWAL, INC. assumes no responsibility for the product's suitability for a particular application. The product must be properly applied to work correctly.
If you need more information on this product, or if you have a particular problem or question, contact KIDDE-FENWAL, INC., Ashland, MA 01721. Telephone: (508) 881-2000.