

# Fenwal Engineered Fire Suppression System

Designed for use with 3M™ Novec™ 1230 Fire Protection Fluid

Pressure Operated Switch, Explosion Proof Data Sheet

F-44-5190



A UTC Fire & Security Company

P/N: 981332

## FEATURES

- For use with UL Listed, ULC Listed, and FM Approved Systems

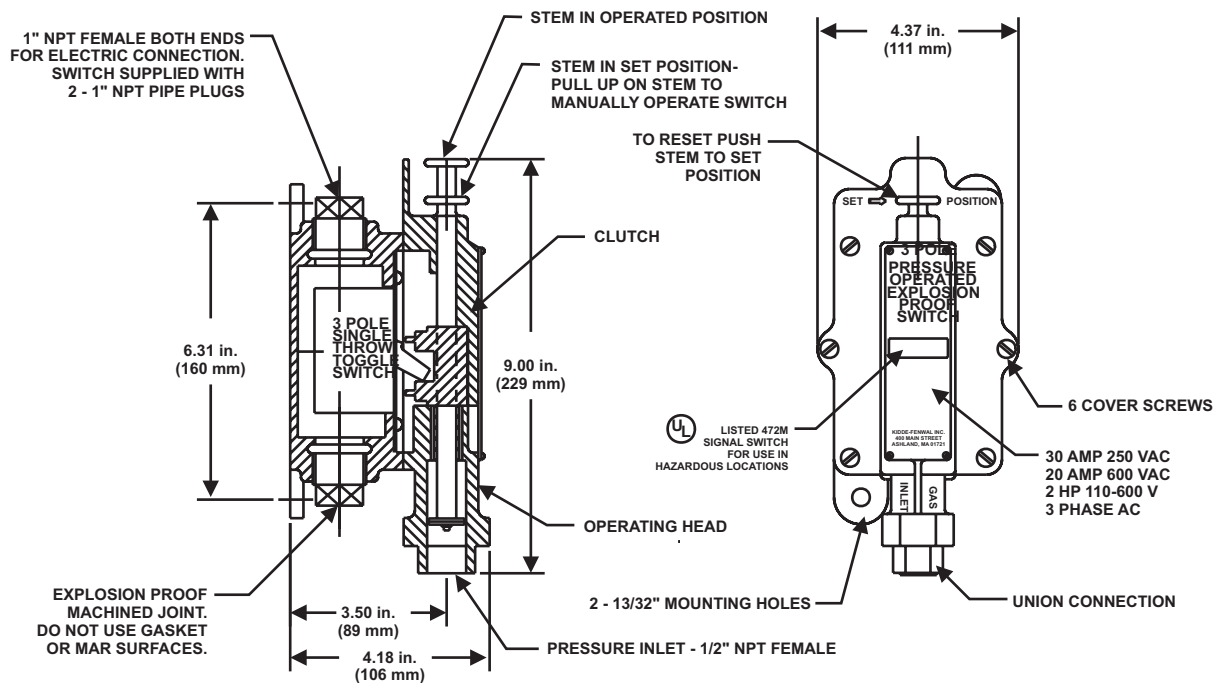

## NOTES

- The toggle switch may be mounted in the base for either Normally Open to Normally Closed or Normally Closed to Normally Open contact transfer upon operation. The illustration above shows the position of the toggle when the switch is in the set position.
- Any load connected to the switch must not exceed the switch rating and shall utilize a suitable protection device (i.e., circuit breaker, fuse).
- Remove the operating head to make electrical connections to the toggle switch. When replacing the operating head, ensure that the toggle engages the clutch. Tighten the cover screws securely.
- Class I, Group D Caution: To prevent ignition of hazardous atmospheres, disconnect the device from the supply circuit before opening. Keep the assembly tightly close when in operation.

Fenwal is a registered trademark of Kidde-Fenwal, Inc.  
3M and Novec are trademarks of 3M.  
All other trademarks are property of their respective owners.

This literature is provided for informational purposes only. KIDDE-FENWAL, INC. assumes no responsibility for the product's suitability for a particular application. The product must be properly applied to work correctly.

If you need more information on this product, or if you have a particular problem or question, contact KIDDE-FENWAL, INC., Ashland, MA 01721. Telephone: (508) 881-2000.